

Introduction

For years, cesium beam frequency standards have been constantly improved so as to satisfy the increasingly stringent specification of time and frequency reference equipments. The availability of "easy to operate" instrument of reduced size and weight and of exceptional accuracy and stability provides the user with great flexibility in using cesium standards for meeting the stringent requirements of navigation, communication and timing systems.

The **Oscilloquartz's 3230** Cesium Clock is an atomic frequency standard based on a hyperfine transition in the ground state of the cesium 133 atom.

Highlights

The **Oscilloquartz's 3230** Cesium Clock is specifically designed and produced with the latest technology in a very compact and reduced size.

Taking into consideration its unique reduced volume, the **Oscilloquartz's 3230** offers a set of operation features and performance without comparison on the market.

Available in two different versions, the long life cesium tube will meet the requirements where performances are needed over a long period of time whereas the high performance version will meet the most exigent applications.

Features

- Allan deviation $\sigma_{(T)} = 2.7 \times 10^{-11} T^{-1/2}$ for long life version and $\sigma_{(T)} = 8.5 \times 10^{-12} T^{-1/2}$ for high performance version
- Front or Rear access connectors
- 3U high (133mm / 5.24") — less than 200mm depth, compatible with ETSI and 19" standards
- Accuracy better than $\pm 1 \times 10^{-12}$ / $\pm 5 \times 10^{-13}$ for high performance version
- 10 MHz low noise direct output
- Programmable 1 / 5 / 10 MHz TTL output
- 10 years warranty on cesium tube (3 years for high performance version)
- Redundant DC power supply inputs
- Remote control and monitoring via RS232 (fully manageable locally and remotely using SyncView Plus management system).



OSA3230 Front access connector

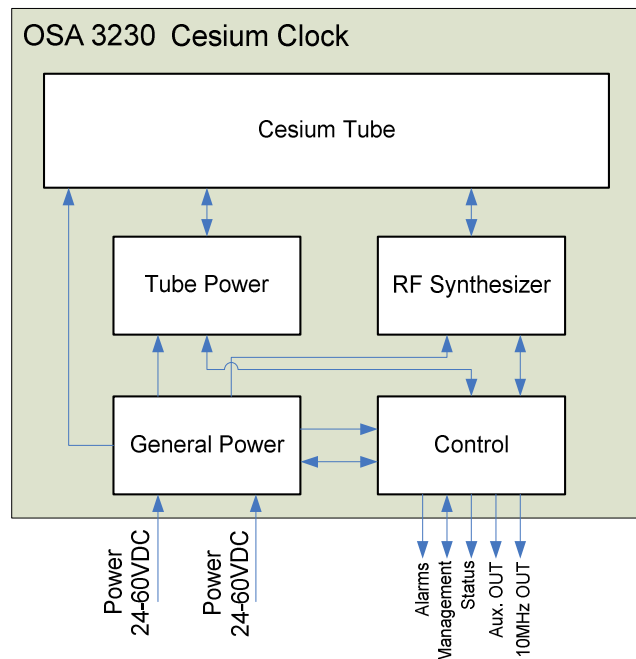

Typical Applications

- Calibration of laboratory's equipment
- Reference for microwaves applications
- Interferometry, Spatial applications
- Nanometrology, medical devices, semiconductors
- Reference source for Navigation and localization systems

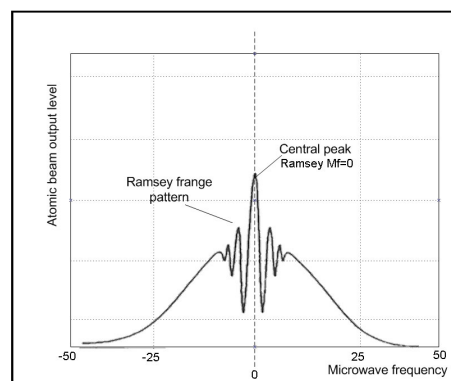

Typical atomic beam current from which the clock signal is derived (central peak)

OSA 3230 Cesium Clock

The OSA 3230 as Metrological Reference Clock Source using the Digital Cesium technology

Typical Characteristics

Cesium performances characteristics

	<u>Std version</u>	<u>High Perf</u>
Frequency accuracy	$\pm 1 \times 10^{-12}$	$\pm 5 \times 10^{-13}$
Frequency deviation over full operating conditions -5°C to +55°C	$\pm 2 \times 10^{-12}$	$\pm 2 \times 10^{-12}$
Reproducibility	$\pm 1 \times 10^{-12}$	$\pm 5 \times 10^{-13}$
Short Term Stability (ADEV):		
	<u>Std version</u>	<u>High Perf</u>
1s	1.2×10^{-11}	5.0×10^{-12}
10s	8.5×10^{-12}	2.7×10^{-12}
100s	2.7×10^{-12}	8.5×10^{-13}
1'000s	8.5×10^{-13}	2.7×10^{-13}
10'000s	2.7×10^{-13}	8.5×10^{-14}
100'000s	8.5×10^{-14}	2.7×10^{-14}
Floor	5×10^{-14}	2×10^{-14}
Stability:		
Resolution	$< 1 \times 10^{-14}$	
Range	$\pm 1 \times 10^{-9}$	
Warm-up time	45 minutes	

Outputs

Direct frequency output

Frequency	10MHz
Output level	7dBm @ 50Ω
Connector	BNC
Output phase noise:	
1 Hz	-90 dBc
10 Hz	-120 dBc
100 Hz	-135 dBc
1 kHz	-145 dBc
10 kHz	-145 dBc
100 kHz	-145 dBc

Harmonic distortion:

Harmonics	> 30 dBc
Spurious	> 70 dBc

Programmable auxiliary output

Frequency	1 / 5 / 10MHz
Output level	0 / 5V HCMOS (square)
Connector	BNC

Power Supply

DC Power input:

Voltage	48V DC nominal floating (24V to 60V)
Power feeds	Dual
Power consumption	40W @ 25°C (warm-up max. 50W)

Management

Communication port

Port	2x RS-232C on SUBD-9 (front + rear) for local management or remotely using SyncView Plus™ Management System and UMI (Universal Management Interface)
------	--

Alarms

Relay contacts	3 x alarm indication
----------------	----------------------

Front panel LED indication

Normal operation	Green
Warm-up	Green-blinking
Standby mode	Yellow
Initialization	Red-blinking
Alarm	Red

Mechanical

Size (H x W x D)	19": 132 x 483 x 192 mm (5.19" x 19" x 7.56") ETSI: 132 x 535 x 192 mm (5.19" x 21.8" x 7.56")
Mounting	3U high 19" or ETSI mounting Rear or Front Access connectors
Weight	< 12kg (excluding packing)

Environmental Conditions

Temperature:	
Operating	- 5°C to +55°C
Non-Operating	- 40°C to +70°C
Humidity	Up to 95%
Altitude (operating)	0 to 15'000m (0 to 50'000 feet)
DC magnetic field	±2 Gauss
EMC & ESD	EN 50081-1, EN 50082-1 IEC 801 parts 2, 3, 4, 5 and 6
Safety	EN 61010-1
Other conditions as per	EN 300 019-1-1, cl. 1.1 EN 300 019-1-2, cl. 2.2 EN 300 019-1-3, cl. 3.2

Oscilloquartz SA reserves the right to change all specifications contained herein at any time without prior notice.

A COMPANY OF THE  SWATCH GROUP